

# Harbor Soaring Society Newsletter

February, 2000

## Inside this issue:

President's Message	1
January Meeting Minutes	1
Treasure's Report	2
Next Contest: Feb. 13 (Sunday)	2
Construction Article	4

## President

Larry Jolly

714-826-6861

## Vice President

Jim Hanson

909-646-3603

## Secretary

Les Kenyon

714-404-3832

## Treasurer

Larry Reed

714-838-5569

## Newsletter Editor

John Brown

714-537-7821

[www.1hss.org](http://www.1hss.org)

## President's Message

I want to take this opportunity to wish you all a happy new year, and to encourage you to rejoin the Harbor Soaring Society, and come out and fly with us. We have some fun things planned this year and want you to be part of it. I want to remind everyone that the Phoenix Contest takes place the weekend after our meeting Feb 5-6. Consequently the field will be open for practice and fun flying all weekend. If you aren't traveling over to Phoenix then you can get a whole weekend of practice for Tom Copp's contest on February 13. We

are starting to get entries for the F3J Contest March 18 and 19. It looks like a good bet that the Canadian F3J Team is showing up. I will be starting a sign-up sheet at the meeting for those of you who would like to volunteer to help out with timing and landing judging. If any one out there has an idea that you would like to see followed up, please contact one of the Club officers and share your idea with us, with everyone pulling together there is no limit to what we can accomplish this year. See you at the meeting.

Larry Jolly

## January Minutes

7:05 President Larry Jolly called the 2000 Board to order; Present were Larry Jolly - President  
Jim Hanson - Vice President  
Les Kenyon - Secretary  
Larry Reed - Treasurer.  
Rodger MacGreagor - General Director  
Ross Thomas - CD  
Joey Rodriguez- Assistant CD

It was agreed that Joe Rodriguez would represent us at the SC2 rules meeting this month.

Joe will CD the monthly contest and Ross will CD the SC2 and all major contest, (Hand toss, major one day- Three function, two day- also an F3J formatted contest. Dates to be worked out. Larry wants a different CD for each month- See Joe or Ross if interested.

Joe Rodriguez donated a lap top computer to the club for contest scoring. We are looking for contest scoring soft

ware, if you see anything on the Web let Joe or Ross know.

7:35 Board meeting adjourned

7:35 General meeting called to order by Larry Jolly- President

Larry introduced himself and first became a member in our club at age 14 way, way back in 1967. Two new members introduced themselves- Jay & John.

Rodger Macgregor, Our Parks Dept Liaison, reported that the consultant hired by the City to assess our impact on the Park, said that HSS is good for the planed Park and the city approved that our location remain exactly were it is, with a grass landing area. Larry will talk about what F3J is all about, next month

Larry Reed, Treasurer reported that in

*(Continued on page 2)*

(Continued from page 1)

1999 the Club spent \$700 more than we took in all year. The shortage came out of our savings account.

Larry Jolly thrilled us by flying his new electric Helicopter around the meeting room. Bring that model your working on for show and tell next month.

## February Contest

C.D. Tom Copp

4 rounds for 30 minutes. 1 round must be a 10 minute flight. All rounds must land "on the minute". Each round is scored 1000 pts. (flight + landing) (900-100,950-50,990-10,??-??) 1 point per second penalty off the minute. 100 points per minute off the 30 minute total. Only full minutes count toward the 30 minute goal.

ex #1: a 4:29 flight is scored as a 4 minute flight and you have 26 minute left.

Jim Hanson, Vice President, Set up his lap top and cut AMA #s for all who were there.

Meeting adjourned at 8:35

ex #2: A 4:30 is scored as a 5 minute flight and you have 25 minutes left. "Open winches" you can fly the next round if #1 your freq is open. #2 you have your last round scored by the scorekeeper. No limit on duration. What do you think? This is set up for pilot thinking. You make the decision in the air as what your time will be for that round. The average flight time per round is 6.6 minutes. 30 minute goal-1. 10 minute flight = 3 flights for 20 minutes = 6.666666667 flight minutes average per round.

## Treasurers Report

11/1/99 Through 1/31/00

Sub-category	11/99	12/99	1/00	Total
<b>Income</b>				
Contest Income				
Club Contest	29.00	132.00	161.00	
Total Contest Income		29.00	132.00	161.00
Investment Income				
Interest	11.88		11.88	
Total Investment Income		11.88		11.88
Membership Dues				
Dues 2000	85.00	485.00	570.00	
Total Membership Dues		85.00	485.00	570.00
Xmas Party Ticket Sales		1,143		1,143
<b>Total Income</b>	<b>1,268.88</b>	<b>617.00</b>		<b>1,885.88</b>

<b>Expenses</b>				
Christmas Party				
Bar Cost		53.88		53.88
Venue Payment		500.00	613.00	1,113
Year End Trophies/Plaques			151.04	151.04
Total Christmas Party		500.00	817.92	1,317.92
Contest Expense				
Trophies		66.00		66.00
Total Contest Expense		66.00		66.00
Field Maintenance				
Electrical		388.21	388.21	
Total Field Maintenance		388.21	388.21	
Internet				
Registration		85.79	85.79	
Total Internet		85.79	85.79	
Miscellaneous		22.00	22.00	

Newsletter				
Postage		33.00		33.00
Printing	138.53			138.53
Total Newsletter	138.53	33.00		171.53
P.O. Box		44.00		44.00
<b>Total Expenses</b>	<b>638.53</b>	<b>1,272.13</b>	<b>184.79</b>	<b>2,095.45</b>

Income less Expenses (638.53) (3.25) 432.21  
(209.57)

**NOTICE NOTICE NOTICE NOTICE**

The deadline for articles to be submitted to the next newsletter is Friday, January 21. Submit by email to the editor, John Brown  
john\_brown@pacbell.net

**NOTICE NOTICE NOTICE NOTICE**

# Product Review

## Hoopes Designs wing connectors

While doing my pre season tune up I noticed there were intermittent problems with my flap servo no power. The solder joint had broken again from the dean's connector, this can be a major problem. The last time this happen was at Visalia where a quick field repair was in order. Tom Hoopes was very helpful and pulled out his trusty butane soldering iron and fixed my plane on the spot. This is when he took the opportunity to show me his wares and said this would cure the problem. The dean's connector gets tugged pulled every time you setup your plane with this abuse over time eventually it will fail the dork landings don't help either. Tom has several versions to fit your needs. I ordered a basic kit, gold pins and wipers. He also has a complete kit with the connectors pre wired so all you have to do is just connect them to your servos, great for your new project. The kit arrives complete with itemized list, instructions, jig and shrink tubing. The gold pins are on a PCB "printed circuit board" and mounted to the fuselage by stainless screws, looks very trick. The female connector mounts flush on the wing root rib. Tom has put much thought in this product. I will not go through the install process here but the average modeler can do a conversion in an evening, took me the entire weekend but that's another problem. Now all I do is just slide the wings on the wing rod to bring in contact with the female housing tape and I'm ready to go flying. The wires are no longer being stressed and my model is now quick to break down when you're ready to go home. The price of the basic gold kit is \$17.75 the deluxe wired gold kit is \$22.50 a drop in the bucket for today's models don't forget to add \$3.00 for shipping. If you want further information RCM has a review in November 1996 issue on page 16.

*Joe Rodriguez*

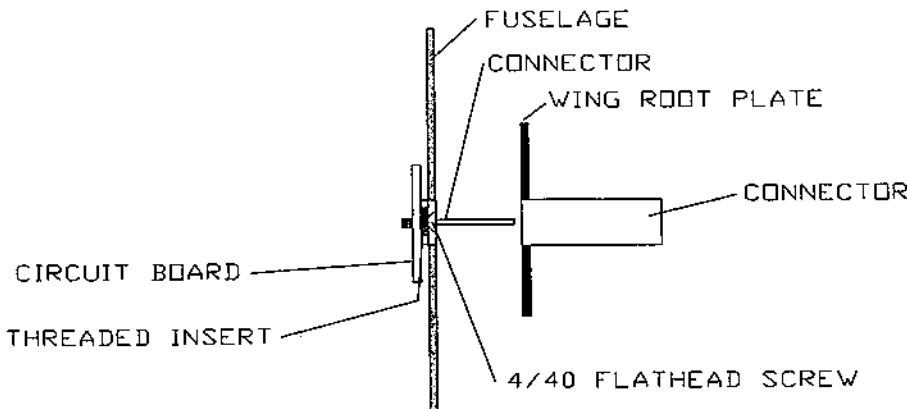
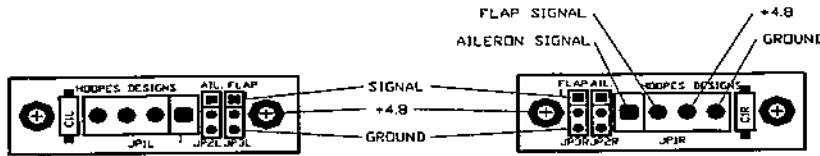

Tom Hoopes  
P.O. Box 2504  
Sandy, Utah 84091-2504  
(801) 571-4209  
oakley@xmission.com

HOOPES DESIGNS		
P. O. BOX 2504		
SANDY, UTAH 84091-2504 U. S. A.		
EMAIL: OAKLEY@XMISSION.COM		
COPYRIGHT 1993		
Title		
WING SERVO CONNECTOR PCB		
Size	Document Number	REV
A	C127-001	1.0
Date:	DECEMBER 12, 1997	Sheet 1 of 1

JOHN J. BROWN  
12442 EL REY PLACE  
GARDEN GROVE CA 92640



DEL KAHAN  
P.O. Box 1501  
Newport Beach, CA 92659

